

**ZDMB6 ENCLOSURE ASSEMBLY
UNLOADED (STANDARD)**

"OPTICAL CABLE CORPORATION (OCC)
RESERVES THE RIGHT TO REVISE ANY
AND ALL DESIGN SPECIFICATIONS."
UNCONTROLLED COPY

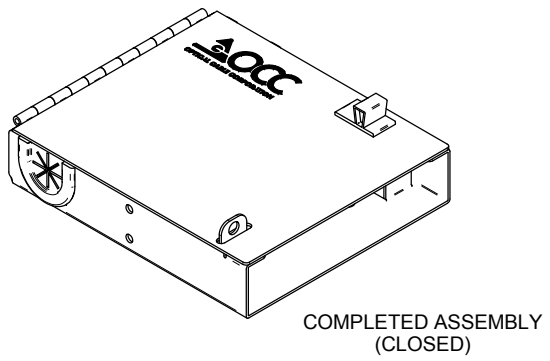
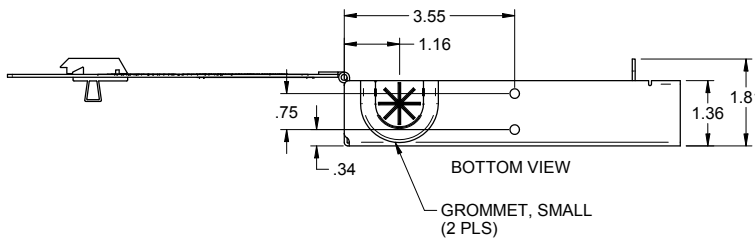
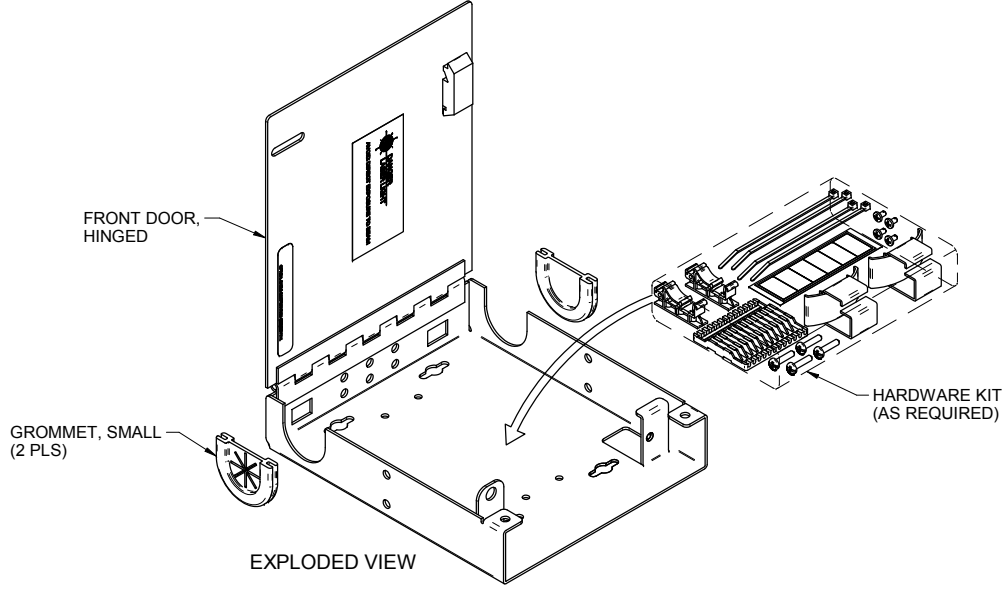
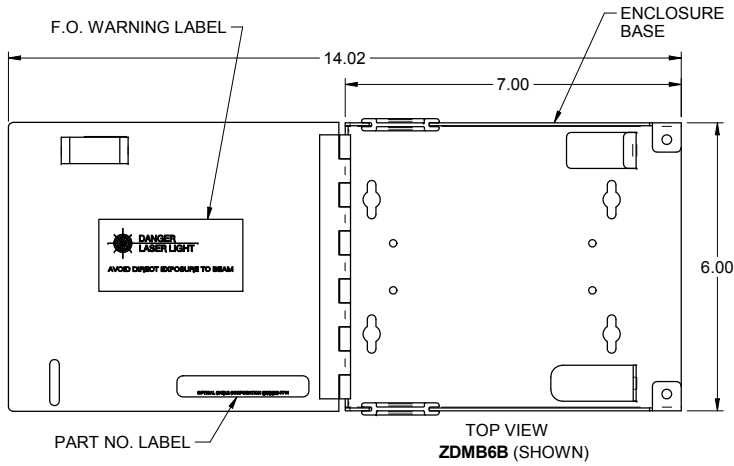
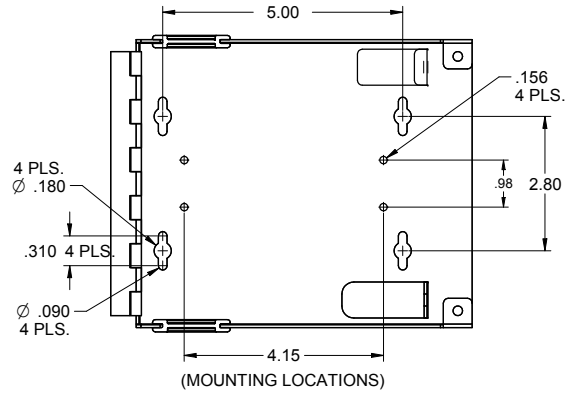

NOTES: UNLESS OTHERWISE SPECIFIED.

- ENCLOSURE COLOR AVAILABLE: "B"=BLACK.
- INSTRUCTION SHEET (1) AND HARDWARE KIT (1) ARE INCLUDED IN ENCLOSURE IN AN INDIVIDUAL PACKAGE.
- CABLE HOLDERS AND OTHER PLASTIC MATERIAL PARTS MEET UL 94 V-0 P.P.O.

THIRD ANGLE PROJECTION CRITICAL DIMENSION CODE (F) = FUNCTION (M) = MATING (A) = AUDIT	UNLESS OTHERWISE SPECIFIED, THIS DRAWING AND THE DESIGN SHOWN ARE THE PROPERTY OF OPTICAL CABLE CORPORATION AND MAY NOT BE USED AS THE BASIS FOR MANUFACTURE OR SALE WITHOUT SPECIFIC WRITTEN PERMISSION OF OPTICAL CABLE CORPORATION. DIMENSIONS ARE IN INCHES. TOLERANCES: FRACTIONS ±1/32" ANGLES ±1/2" 3 PLACE DECIMALS ±.005" 2 PLACE DECIMALS ±.01"	DRAWN D.A.HOLBERT DATE 4/19/09 CHECKED R.B.SMITH DATE 11/21/09 ENGINEER J.YANIK DATE 4/19/09 APPROVED J.HOWE DATE 11/21/09	DWG TITLE ZONE DISTRIBUTION BOX (STANDARD)	33 Superior Way Swannanoa, NC 28778 Phone: 828-298-2260 Fax: 828-298-2487 www.occfiber.com
	MATERIAL SEE BILL OF MATERIAL FINISH SEE NOTES FILENAME C:109583D.dft	PREVIOUS DWG NEXT DWG	SIZE C DWG NO. C109583 REV D SCALE: NONE SHEET 1 OF 1	PROPRIETARY AND CONFIDENTIAL